

BOLTED BONNET TYPE GATE VALVES

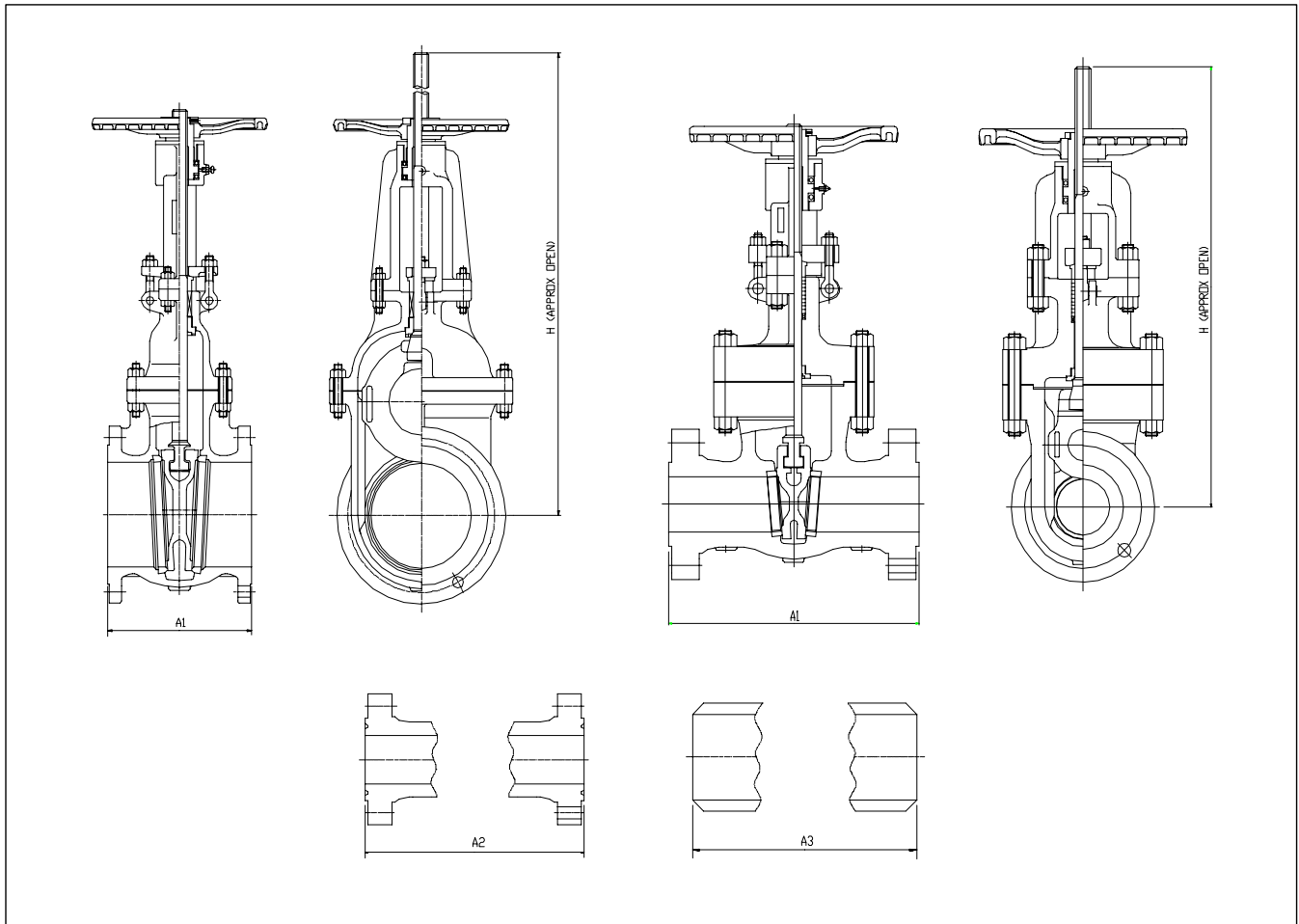

NO.	NAME OF PART	ASTM MATERIAL									
		STANDARD	HIGH TEMP. SERVICE			LOW TEMP. SERVICE	STAINLESS STEEL		ALLOY STEEL		
1	BODY	A216-WCB	A217-WC6	A217-WC9	A217-C5	A352-LCB	A351-CF8	A351-CF8M	A351-CN7M	A351-CK3MCUN	
2	BONNET	A216-WCB	A217-WC6	A217-WC9	A217-C5	A352-LCB	A351-CF8	A351-CF8M	A351-CN7M	A351-CK3MCUN	
3	WEDGE	A217-CA15	A217-WC6	A217-WC9	A217-C5	A352-LCB	A351-CF8	A351-CF8M	A351-CN7M	A351-CK3MCUN	
4	BODY SEAT RING	A105 + H.F	A182-F11	A182-F22	A182-F5a	A182-F304	A182-F304	A182-F316	A351-CN7M	A182-F51	
5	STEM	A276-410	A276-410	A276-410	A276-410	A276-304	A276-304	A276-316	ALLOY 20	A182-F51	
6	BONNET BUSH	A276-410	A276-410	A276-410	A276-410	A276-304	A276-304	A276-316	ALLOY 20	A182-F51	
7	PACKING GLAND	A276-410	A276-410	A276-410	A276-410	A276-304	A276-304	A276-304	A276-304	A276-304	
8	GLAND FLANGE	A105 OR A283 - D					A351-CF8 (304SS)				
9	YOKE SLEEVE	A439 - D2C					AL-BRONZE				
10	BONNET BOLT	A193 - B7	A193 - B16	A193 - B16	A193 - B16	A320 - L7	A193 - B8	A193 - B8	A193 - B8	A193 - B8	
11	BONNET NUT	A194 - 2H	A194 - 4	A194 - 4	A194 - 4	A194 - 4	A194 - 8	A194 - 8	A194 - 8	A194 - 8	
12	GLAND BOLT	A307 - B					A193 - B8				
13	GLAND NUT	A307 - B					A194 - 8				
14	HINGE PIN	A108 - 1020					A276-304				
15	LANTERN RING	A276-410			A276-304		A276-304	A276-316	ALLOY 20	A182-F51	
16	YOKE	A216-WCB					A351-CF8				
17	YOKE BOLT	A193 - B7					A193 - B8				
18	YOKE NUT	A194 - 2H					A194 - 8				

MAIN DIMENSIONS & WEIGHT (CLASS 150)

VALVE SIZE	in	2	2.5	3	4	6	8	10	12	14	16	18	20	24	28	30	36	40	42	
	mm	50	65	80	100	150	200	250	300	350	400	450	500	600	700	750	900	1000	1050	
A1	in	7.0	7.5	8.0	9.0	10.5	11.5	13.0	14.0	15.0	16.0	17.0	18.0	20.0	24.0	24.0	28.0	30.0	31.0	
	mm	178	190	203	229	267	292	330	356	381	406	432	457	508	610	610	711	762	813	
A3	in	8.5	9.5	11.12	12.0	15.87	16.5	18.0	19.75	22.5	24.0	26.0	28.0	32.0	36.0	36.0	40.0	42.0	43.0	
	mm	216	241	283	305	403	419	457	502	572	610	660	711	813	914	914	1016	1067	1092	
H	in	15.2	16.5	17.9	22.6	30.4	38.2	46.2	54.3	59.7	68.5	78.9	91.2	109.2	127.1	134.6	160.3	169.3	174.3	
	mm	386	419	455	574	772	970	1173	1379	1516	1740	2004	2316	2774	3228	3419	4072	4300	4427	
W	in	7.9	7.9	7.9	9.8	11.8	14.0	17.7	17.7	19.7	22.0	13.8	17.7	17.7	22.0	22.0	27.9	31.5	31.5	
	mm	200	200	200	250	300	355	450	450	500	560	350	450	450	560	560	710	800	800	
L	in											13.1	14.3	14.3	16.3	16.3	18.4	20.7	20.7	
	mm											333	363	363	414	414	467	526	526	
WEIGHT	RF	lb	46	55	66	99	181	267	417	600	794	1151	1356	1667	2675	4229	4465	7781	9495	10121
		kg	21	25	30	45	82	121	189	272	360	522	615	756	1213	1918	2025	3529	4306	4590
	BW	lb	42	46	64	93	148	247	384	584	761	1103	1305	1660	3233	4628	4893	8282	10198	10222
		kg	19	21	29	42	67	112	174	265	345	500	592	753	1466	2099	2219	3756	4625	4636

MAIN DIMENSIONS & WEIGHT (CLASS 300)

VALVE SIZE	in	2	2.5	3	4	6	8	10	12	14	16	18	20	24	28	30	36	40	42	
	mm	50	65	80	100	150	200	250	300	350	400	450	500	600	700	750	900	1000	1050	
A1 & A3	in	8.5	9.5	11.12	12.0	15.88	16.5	18.0	19.75	30.0	33.0	36.0	39.0	45.0	53.0	55.0	68.0	76.0	78.0	
	mm	216	241	283	305	403	419	457	502	762	838	914	991	1143	1346	1397	1727	1930	1981	
A2	in	9.12	10.12	11.75	12.62	16.50	17.12	18.62	20.37	30.62	33.62	36.62	39.75	45.88	54.00	56.00	69.12			
	mm	232	257	298	321	419	435	473	518	778	854	930	1010	1165	1372	1422	1756			
H	in	16.1	17.5	18.8	23.5	31.9	40.3	48.7	56.9	66.0	78.4	85.6	93.5	112.8	129.7	148.1	170.1	188.3	197.6	
	mm	409	445	478	597	810	1024	1237	1445	1676	1991	2174	2375	2865	3294	3762	4321	4783	5019	
W	in	7.9	7.9	8.8	9.8	14.0	15.7	17.7	19.7	17.1	17.7	22.0	22.0	27.9	35.4	35.4	30.0	30.0	30.0	
	mm	200	200	224	250	355	400	450	500	450	450	560	560	710	900	900	760	760	760	
L	in									14.3	14.3	16.3	16.3	18.4	21.8	21.8	21.8	20.2	20.2	
	mm									363	363	414	414	467	554	554	554	513	513	
WEIGHT	RF	lb	57	82	101	157	309	476	657	1019	1530	2145	2838	3380	5281	7929	9389	15040	17924	20365
		kg	26	37	46	71	140	216	298	462	694	973	1287	1533	2395	3596	4258	6821	8129	9236
	BW	lb	53	73	84	126	260	381	523	842	1297	1863	2417	2891	4481	6738	7914	11307	13223	14628
		kg	24	33	38	57	118	173	237	382	588	845	1096	1311	2032	3056	3589	5128	5997	6634

MAIN DIMENSIONS & WEIGHT (CLASS 600)

VALVE SIZE	in	2	2.5	3	4	6	8	10	12	14	16	18	20	24	28	30	36	40	42	
	mm	50	65	80	100	150	200	250	300	350	400	450	500	600	700	750	900	1000	1050	
A1 & A3	in	11.5	13.0	14.00	17.0	22.00	26.0	31.0	33.00	35.0	39.0	43.0	47.0	55.0	61.0	65.0	82.0	94.0	98.0	
	mm	292	330	356	432	556	660	787	838	889	991	1092	1194	1397	1549	1651	2083	2387	2489	
A2	in	11.62	13.12	14.12	17.12	22.12	26.12	31.12	33.12	35.12	39.12	43.12	47.25	55.38	61.50	65.50	82.62			
	mm	295	333	359	435	562	664	791	841	892	994	1094	1200	1406	1562	1663	2098			
H	in	18.6	19.4	22.3	26.5	37.4	43.5	51.8	65.5	71.6	83.2	98.2	104.2	116.7	140.3	152.6	179.6	207.9	239.8	
	mm	472	493	566	673	950	1105	1316	1664	1819	2113	2494	2647	2964	3564	3876	4562	5281	6091	
W	in	8.8	8.8	9.8	11.8	17.7	19.7	24.8	22.0	22.0	27.9	27.9	31.5	35.4	30.0	30.0	30.0	30.0	30.0	
	mm	200	200	224	250	355	400	450	500	450	450	560	560	710	900	900	760	760	760	
L	in								16.3	16.3	18.4	18.4	20.7	26.4	20.2	20.2	20.2	20.2	20.2	
	mm								414	414	467	467	526	671	513	513	513	513	513	
WEIGHT	RF	lb	86	128	152	284	600	961	1480	2256	2840	3958	5221	6604	10103	13089	15713	21748	24017	24773
		kg	39	58	69	129	272	436	671	1023	1288	1795	2368	2995	4582	5936	7126	9863	10892	11235
	BW	lb	62	90	130	225	437	712	1217	2040	2611	3371	4736	5757	8813	10868	13512	18877	21201	22524
		kg	28	41	59	102	198	323	552	925	1184	1529	2148	2611	3997	4929	6128	8561	9615	10215

MAIN DIMENSIONS & WEIGHT (CLASS 900)

VALVE SIZE	in	2	2.5	3	4	6	8	10	12	14	16	18	20	24	
	mm	50	65	80	100	150	200	250	300	350	400	450	500	600	
A1 & A3	in	14.5	16.5	15.0	18.0	24.0	29.0	33.0	38.0	40.5	44.5	48.0	52.0	61.0	
	mm	368	419	381	457	610	737	838	965	1029	1130	1219	1321	1549	
A2	in	14.62	16.62	15.12	18.12	24.12	29.12	33.12	38.12	40.88	44.88	48.5	52.5	61.75	
	mm	371	422	384	460	612	740	841	968	1038	1140	1232	1333	1568	
H	in	21.1	26.5	26.5	30.9	42.5	55.5	67.5	77.5	74.9	80.5	88.9	110.5	124.2	
	mm	536	673	673	785	1080	1410	1715	1969	1902	2045	2258	2807	3155	
W	in	11.8	11.8	14.0	15.7	22.0	17.7	22.0	22.0	24.0	24.0	30.0	30.0	24.0	
	mm	300	300	355	400	560	450	560	560	610	610	760	760	610	
L	in						14.3	16.3	16.3	20.2	20.2	21.8	21.8	20.2	
	mm						363	414	414	513	513	554	554	513	
WEIGHT	RF	lb	176	300	351	373	988	1702	2688	3497	4710	6322	8525	10566	15909
		kg	80	136	159	169	448	772	1219	1586	2136	2867	3866	4792	7215
	BW	lb	132	282	267	271	741	1352	2194	2864	3890	5415	7202	8937	13854
		kg	60	128	121	123	336	613	995	1299	1764	2456	3266	4053	6283

MAIN DIMENSIONS & WEIGHT (CLASS 1500)

VALVE SIZE	in	2	2.5	3	4	6	8	10	12	14	16	18	20	24	
	mm	50	65	80	100	150	200	250	300	350	400	450	500	600	
A1 & A3	in	14.5	16.5	18.5	21.5	27.75	32.75	39.0	44.5	49.5	54.5	60.5	66.5	76.5	
	mm	368	419	470	546	705	832	991	1130	1257	1384	1536	1664	1943	
A2	in	14.62	16.62	18.62	21.62	28.0	33.13	39.38	45.12	50.25	55.38	61.38	66.38	77.62	
	mm	371	422	473	549	711	841	1000	1146	1276	1406	1559	1686	1972	
H	in	21.1	26.5	29.2	30.9	46.8	60.6	66.6	82.5	85.6	97.3	108.2	122.3	146.3	
	mm	536	673	742	785	1189	1539	1692	2096	2174	2471	2748	3106	3716	
W	in	11.8	11.8	15.7	19.7	13.8	22.0	27.9	27.9	30.0	30.0	30.0	24.0	24.0	
	mm	300	300	400	500	350	560	710	710	760	760	760	610	610	
L	in					13.1	16.3	18.4	18.4	21.8	21.8	21.8	20.2	20.2	
	mm					333	414	467	467	554	554	554	513	513	
WEIGHT	RF	lb	187	329	399	578	1444	3008	4714	7142	8807	15190	19653	24473	35562
		kg	85	149	181	262	655	1364	2138	3239	3994	6889	8913	11099	16128
	BW	lb	161	276	329	386	1230	2622	3951	6326	7418	13411	16813	21142	29891
		kg	73	125	149	175	558	1189	1792	2869	3364	6082	7625	9588	13556

MAIN DIMENSIONS & WEIGHT (CLASS 2500)

VALVE SIZE	in	2	2.5	3	4	6	8	10	12	
	mm	50	65	80	100	150	200	250	300	
A1 & A3	in	17.75	20.0	22.75	26.5	36.0	40.25	50.0	56.0	
	mm	451	508	578	673	914	1022	1270	1422	
A2	in	17.87	20.25	23.00	26.88	36.50	40.87	50.88	56.88	
	mm	454	514	584	683	927	1038	1292	1445	
H	in	24.4	31.9	31.9	42.2	57.1	63.0	82.5	92.2	
	mm	620	810	810	1072	1450	1600	2096	2342	
W	in	11.8	17.7	17.7	24.8	24.0	24.0	24.0	30.0	
	mm	300	450	450	630	610	610	610	760	
L	in					17.0	20.2	20.2	21.8	
	mm					432	513	513	554	
WEIGHT	RF	lb	209	329	441	1321	3495	5358	10075	15611
		kg	95	149	200	599	1585	2430	4569	7080
	BW	lb	130	218	284	1076	2851	4247	8244	13069
		kg	59	99	129	488	1293	1926	3739	5927